

DATA SHEET neon convertor Type MIDI ECG 4040

- Available in the following versions: *Standard, Dimmer, Flasher, Remote control, Remote dimmer (0-10v)*
- Compliant with standard EN 61347-2-10 for the **L.V. Directive**
- Compliant with standard EN 61000-3-2, EN 55015 3rd ed., EN 61547 for the **EMC Directive**
- **Type B** converter in accordance with EN 61347-2-10 (protection against secondary ground fault leakage is required)
- 230v. input, with Italian or Schuko plug and a 1,5m cable.
- Output with 1m cable type **K** (as per EN 50143). Insulation in polyethylene and PVC. External diameter 4,5mm. Section 1mm²

Electrical data:

Input :	Voltage	Volt 200 - 250
	Current	Ampere 0,35 (at 230v)
	Frequency	Hertz 50/60
	Power	Watt 80
	Power factor	$\lambda > 0.98$

Output:	Voltage	Volt 2.0 – E – 2.0KV rms maximum
	Nominal load current	mA 35
	Short circuit current	mA 40
	Frequency	Hertz 24.500

Performances:

- Not compliant with *Flashers*
- Not compliant with *Dimmers*
- Suitable both for lamps loaded with argon + mercury gas as well as with 100% neon gas (lack of “bubble” effect and of mercury migration)
- Supplied with ***open circuit protection, ground fault protection and protection against overloading***
- Maximum ambient temperature 40 c°
- Place 10mm far from metal surfaces

Indicative chart of maximum loading for electronic converters

For every electrode couple 50cm must be calculated.

	d.8mm	d.10mm	d.12mm	d.15mm	d.18mm	d.20mm	d.25mm
Argon	mt. 5,7	mt. 6,3	mt. 7,1	mt. 8,0	mt. 8,7	mt. 9,1	mt. 9,4
Neon	mt. 4,3	mt. 4,7	mt. 5,4	mt. 6,1	mt. 6,8	mt. 7,5	mt. 7,8

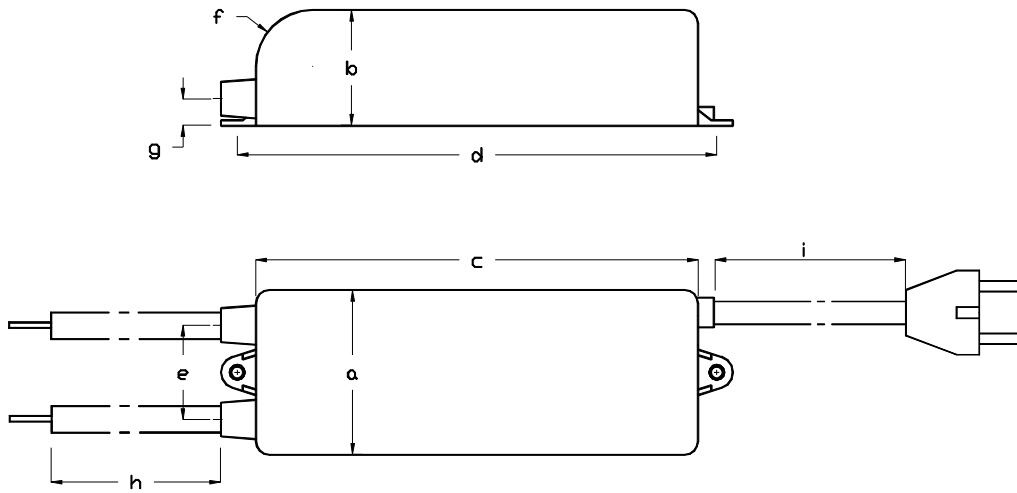

	a	b	c	d	e	f	g	h	i	weight
MIDI	48	35	150	162	25	14	6	1000	1500	650 g

All dimensions are in mm.

INSTALLATION GUIDELINE

- To verify that the converter is not overloaded add to the lamps to be lit a 25 K Ω (11 watt) resistor. If tripping occurs, reduce the number of lamps to feed. To check for presence of installation problems, this test shall be performed when sign is finished.
- For high voltage connections use the cable connected to the transformer with no further additions.
- The converter must be, on all its' sides, **1 cm apart** from the metal surface.
- The converters must be at least **2 cm far** from one another.
- The distance between the lamps and parts with different potential (other lamps, current conductors, parts connected to earth) shall be suitable to the voltages on site which, at the frequencies produced by the converter, can discharge easily through air and unsuitable insulating material.
- The material of the supports of the lamps must be always insulating (EN 50107)
- To comply with the *electromagnetic compatibility* directive (EMC), from the output of the converter to the feeding supply, **avoid placing the feeding cable near the neon lamps and/or the high voltage cables.**

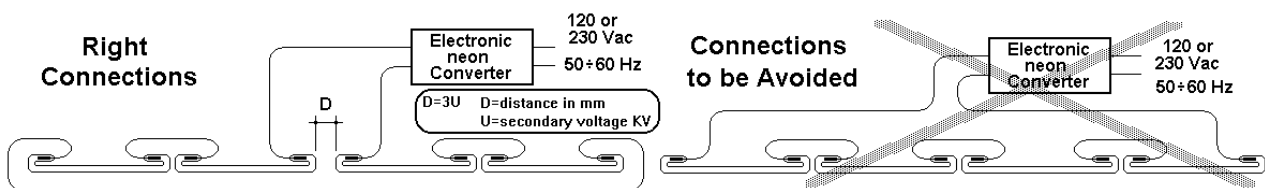

Ozonelux : Warranty conditions

Warranty by Ozonelux srl is limited to faults arising from the components and from the manufacturing process. Faults caused by external sources such as surge condition, improper use of the device and similar not complying with what depicted within the instruction for use provided by Elettronica per Luce srl, are not covered by warranty.

Ozonelux srl provides a two year warranty: this two year guarantee period is from the manufacturing date mentioned on the converter.

The faulty unit shall be returned to Ozonelux carriage paid.

The liability of Ozonelux srl is limited to the sale price of the unit which is found faulty after the control by Ozonelux srl.

Design **Elettronica per luce**

TECNOLUX
GROUP